

EXT Series

1200lbs Water Proof Electromagnetic Lock

Model EXT545-SLCF-A (Monitored Version)

DESCRIPTION

1200lbs Water Proof EM locks were designed as such to be unaffected / resisting the ingress of water under specified condition with its fully sealed electronics incased with stainless steel. This EM Lock series is fitted with cable female. Suitable for outdoor application and harsh climate.



FEATURES & SPECIFICATION



Life Safety Applications



Zero Residual Magnetism



Low Energy Consumption



Cost Savings

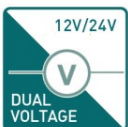

12/24Vdc Selectable



Fully Sealed Electronics

Model	EXT545-SLCF-A
Features & Spec.	
Lock Status Monitoring	Reed Switch
Holding Force	Up to 1200lbs
Magnet Size	222 X 62 X 42 mm
Armature Size	185 X 61 X 16.5 mm
Current Drain	420mA±10%/12Vdc 210mA±10%/24Vdc
Operating Temperature	(-10 to 55) °C (14 to 131) °F
Housing Finishing	Stainless Steel Housing
Est. Weight	4.75kg

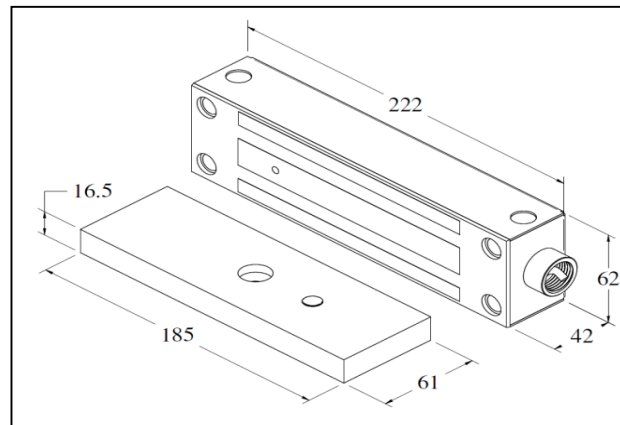

EXT Series

1200lbs Water Proof Electromagnetic Lock

STANDARD INSTALLATION DIAGRAM

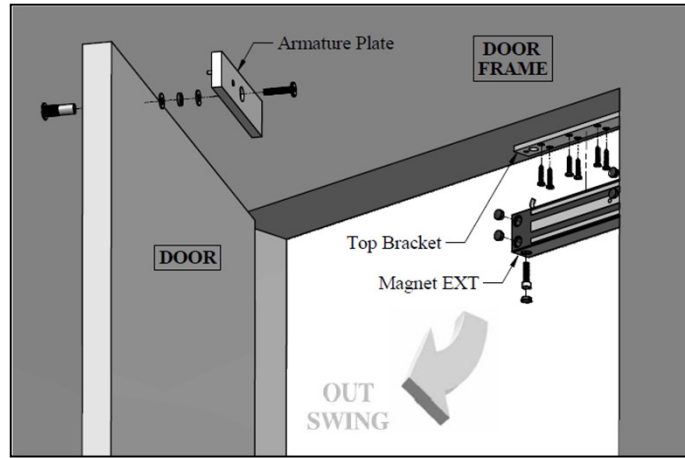

Explode View

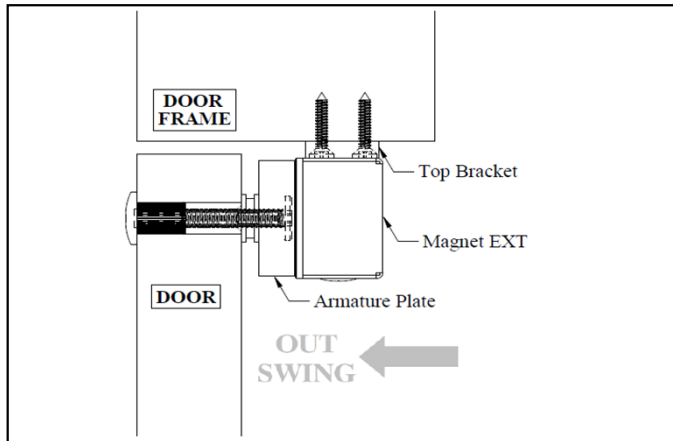

Side View

WIRING DIAGRAM

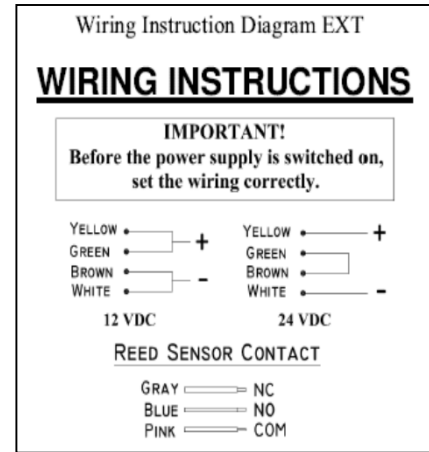

OPTIONAL - BRACKET SELECTION

LS-EXT545	Z-545
-----------	-------