

602 Series



600lbs Double Screw Electromagnetic Lock

Model 602-SL (Monitored Version)

DESCRIPTION

600lbs Double Screw EM locks were designed to meet fire/life safety applications by providing an auxiliary locking mechanism that has no moving parts to bind or wear out for trouble free operation. This will ensure inhibited release at all times where they have become extremely prevalent in applications other than fire/life safety. Double screw type for re-inforce grip. Suitable for access controlled & secure areas within buildings.



FEATURES & SPECIFICATION



Life Safety Applications



No Residual



Low Energy Consumption



Cost Savings



12/24V Selectable



Ideal for all door types

Models	602-SL
Features & Spec.	
Lock Status Monitoring	✓
Holding Force	Up to 600lbs
Magnet Size	251 X 42 X 26 mm
Armature Size	180 X 38 X 11 mm
Current Drain	480mA±10%/12Vdc / 240mA±10%/24Vdc
Operating Temperature	(-10 to 55)°C (14 to 131)°F
Housing Finishing	Anodized Aluminium
Est. Weight	2.0kg

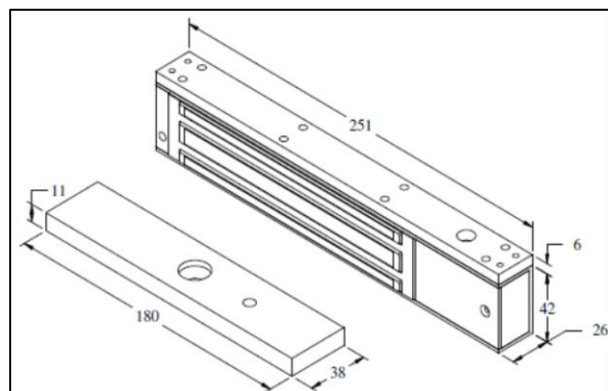

602 Series



600lbs Double Screw Electromagnetic Lock

STANDARD INSTALLATION DIAGRAM

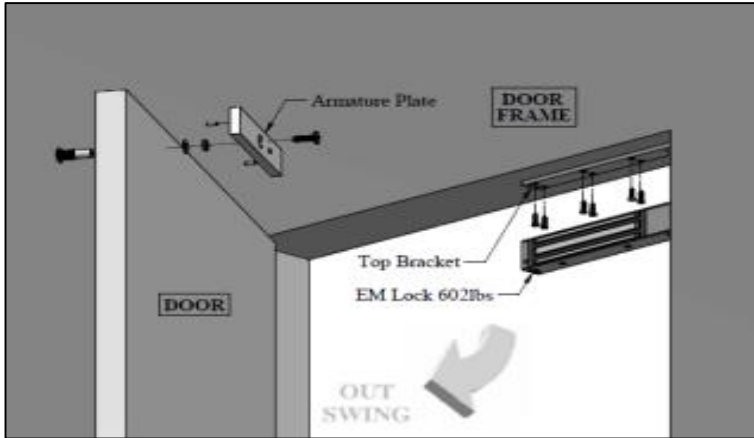

Explode View

WIRING DIAGRAM

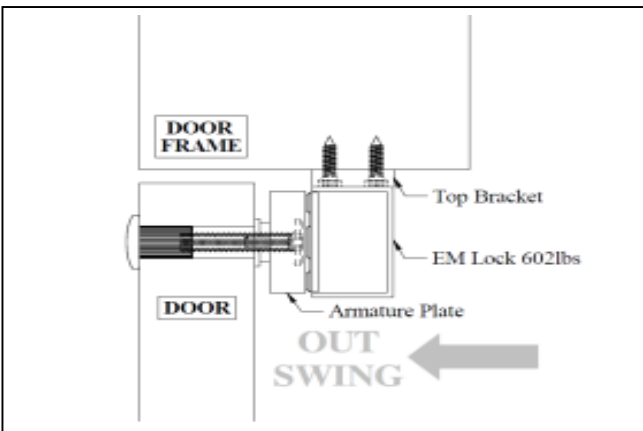
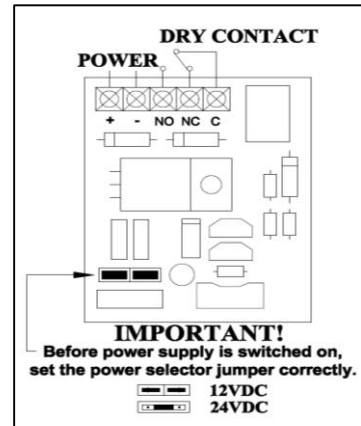

Side View

OPTIONAL - BRACKET SELECTION

U1-275	ZL-602	LS-602	GG-602	AH-275	AB-275
--------	--------	--------	--------	--------	--------