

545 Series

1200lbs Electromagnetic Lock

Model **UL545-S-A (Unmonitored Version)**
UL545-SL-A (Monitored Version)

DESCRIPTION

1200lbs EM Locks were designed to meet fire/life safety applications by providing an auxiliary locking mechanism that has no moving parts to bind or wear out for trouble free operation. This will ensure inhibited release at all times where they have become extremely prevalent in applications other than fire/life safety. Suitable for interior & perimeter doors which requires medium security.



FEATURES & SPECIFICATION



Life Safety Applications



Zero Residual Magnetism



Low Energy Consumption



Cost Savings

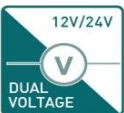

12/24V Selectable



Ideal for all door types

Models	UL545-S-A	UL545-SL-A
Features & Spec.		
Lock Status Monitoring	-	✓
Holding Force	Up to 1200lbs	
Magnet Size	266 X 67 X 40 mm	
Armature Size	185 X 61 X 16.5 mm	
Current Drain	420mA±10%/12Vdc 210mA±10%/24Vdc	
Operating Temperature	(-10 to 55)°C (14 to 131)°F	
Housing Finishing	Anodized Aluminium	
Est. Weight	4.71kg	

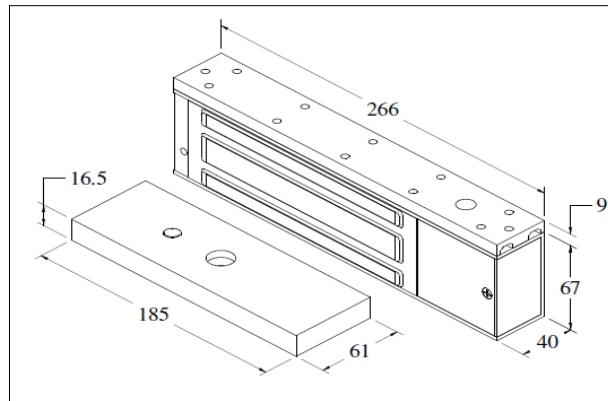

545 Series

1200lbs Electromagnetic Lock

STANDARD INSTALLATION DIAGRAM

WIRING DIAGRAM

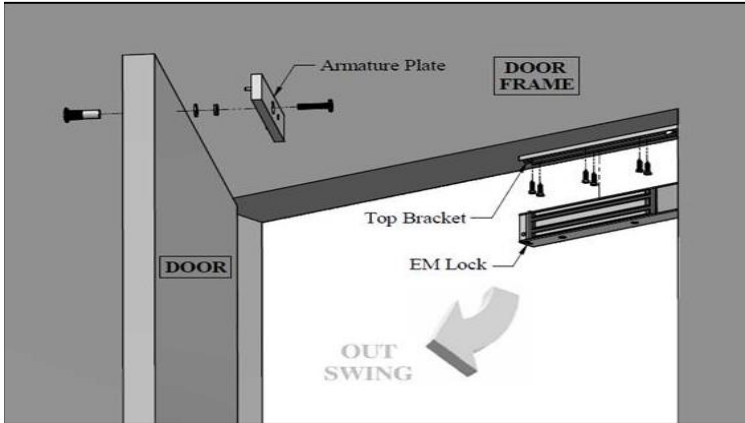

Explode View

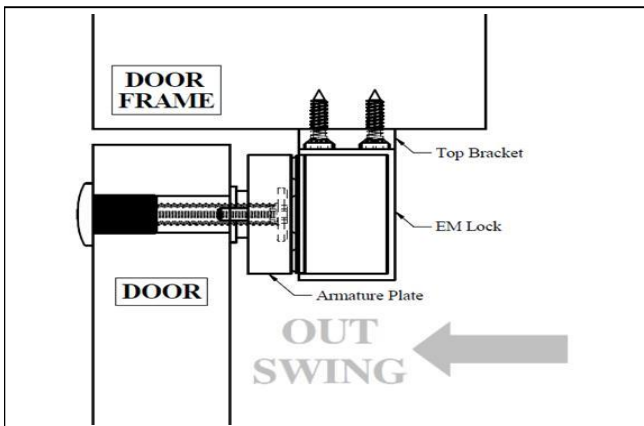
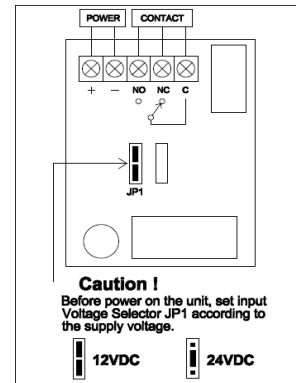

Side View

OPTIONAL - BRACKET SELECTION

LS-545	U1-545	ZL-545	ZLE-545	LSDC-545-G	ZLDC-545-G
AH-545	AB-545				