

# 275C Series

### 600lbs Electromagnetic Lock

**Model** UL275C-S (Unmonitored Version)  
 UL275C-SP (LED with indicating lamp only)

#### DESCRIPTION

C-Series 600lbs EM Locks were designed to meet fire/life safety applications by providing an auxiliary locking mechanism that has no moving parts to bind or wear out for trouble free operation. This will ensure inhibited release at all times where they have become extremely prevalent in applications other than fire/life safety. Suitable for access controlled & secure areas within buildings.

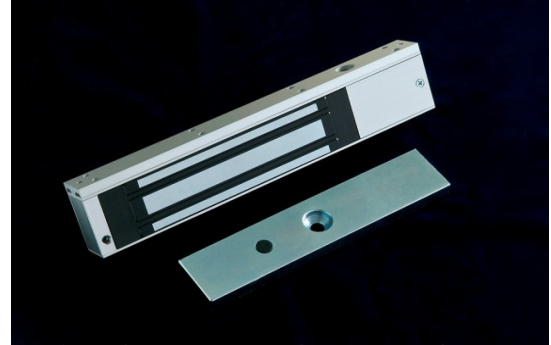

#### FEATURES & SPECIFICATION



**Life Safety Applications**



**Zero Residual Magnetism**



**Low Energy Consumption**



**Cost Savings**

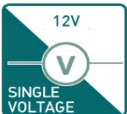

**12Vdc**



**Ideal for all door types**

Models	UL275C-S	UL275C-SP
<b>Features &amp; Spec.</b>		
<b>Lock Status Monitoring</b>	-	-
<b>Indication Lamp</b>	-	LED
<b>Holding Force</b>	Up to 600lbs	
<b>Magnet Size</b>	250 X 42 X 26 mm	
<b>Armature Size</b>	180 X 38 X 11 mm	
<b>Current Drain</b>	500mA±10%/12Vdc	
<b>Operating Temperature</b>	(-10 to 55) °C (14 to 131) °F	
<b>Housing Finishing</b>	Anodized Aluminium	
<b>Est. Weight</b>	2.0kg	

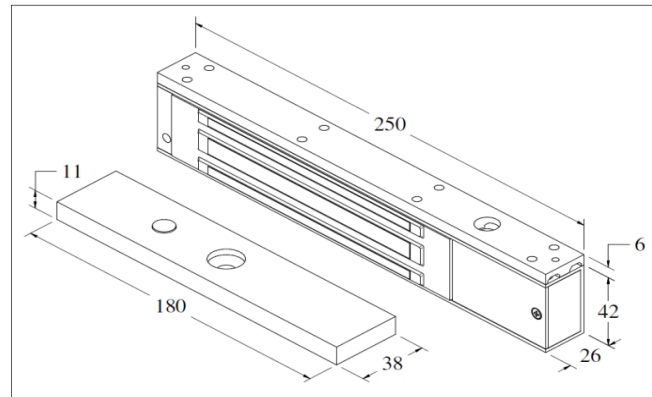

# 275C Series

## 600lbs Electromagnetic Lock

### STANDARD INSTALLATION DIAGRAM

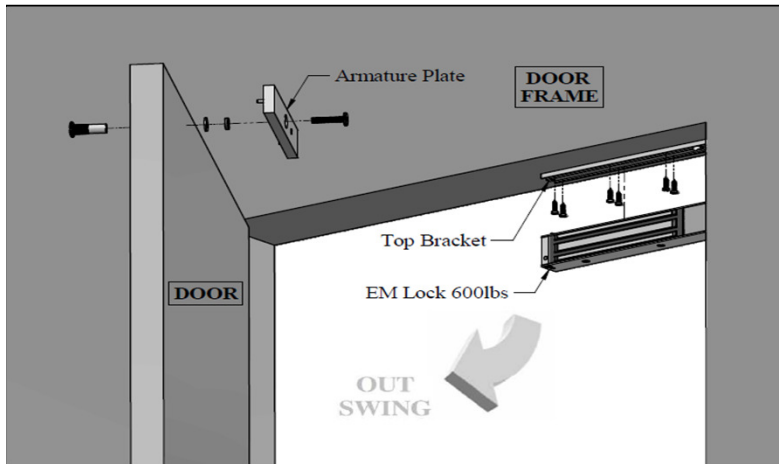

Explode View

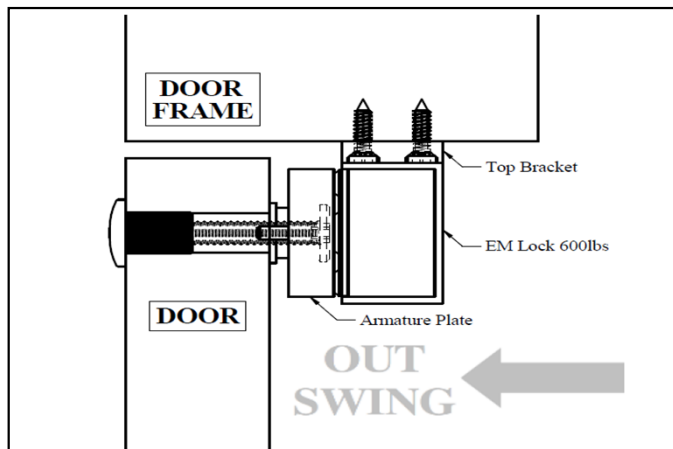

Side View

### OPTIONAL - BRACKET SELECTION

U1-275	ZL-275	ZLE-275	LS-275	GG-275	ZLC-275
ZLC-275-G	ZLDC-275-G	LSDC-275-G	AH-275	AB-275	